



**MULTICRETE HURON 4  
SHOTCRETE  
APPLICATION CARRIER**

**OUR EQUIPMENT, PRODUCTS, PEOPLE:  
SUPPORT *YOU* CAN COUNT ON!**

Winnipeg,MB Redlake,ON Thompson,MB Snowlake,MB Flin Flon,MB Saskatoon,SK Edmonton,AB  
Ph:204-262-5900 Ph:807-735-3011 Ph:204-677-5977 Ph:204-358-7992 Ph:204-687-6533 Ph:306-651-2727 Ph:780-960-6692  
Fx:204-262-5909 Fx:807-735-3012 Fx:204-677-5981 Fx:204-681-6509 Fx:306-651-2728 Fx:780-960-1132

[www.multicretesystems.com](http://www.multicretesystems.com)



www.multicretesystems.com

# Multicrete Huron 4

*Aliva® 257 Shotcrete Machine, AL-302 Spray Arm on a Carrier*

## Multicrete Huron 4 Mobile Shotcrete Application Carrier

A shotcrete carrier which includes a state of the art Aliva 257 wet/dry shotcrete machine on the rear, an Aliva 302 wet mix shotcrete spraying arm on the front, enhanced hydraulics, self contained liquid accelerator storage & pumping system all on a Huron 4 transmixer chassis. A very compact, manueverable, tough unit designed to get the job done!

### Specifications:

#### Huron 4 Transmixer Truck Chassis

Monoblock. Heavy duty type.

#### **Engine**

Diesel CUMMINGS type QSB 4.5 (TIER III-COM III), 4 cylinders, turbo intercooler.

Liquid cooling. Power DIN 116kW (155HP) to 2,200 r.p.m. It is designed to work at 4700 MASL.

#### **Axles**

Monolithic with epicycloids reducer. Dynamic loading capacity per axle 8000 kg.

Steering type front axle with oscillating assembly. Fixed rear axle.



*Figure 1 Aliva 302 Spray Boom (front) and Aliva 257 Wet/Dry Shotcrete Machine (rear) assembled on Huron 4 Transmixer Chassis.*



*Figure 2 Aliva 302 Spray Arm partially extended*



*Figure 3 Mixing Drum and Liquid Accelerator Storage*

#### **Transmission**

Hydrostatic type with automatic regulation. Axial pistons pump of variable flow applied directly to diesel engine. Hydraulic motor at axial pistons mounted on reducer cap.

#### **Steering**

Hydraulic on front axle.

#### **Brakes**

Internal discs oil bathed on front wheels.

Hydraulic activate in two independent circuits.

Parking brakes on transmission with hand lever control.



www.multicretesystems.com

# Multicrete Huron 4

*Aliva® 257 Shotcrete Machine, AL-302 Spray Arm on a Carrier*

## Specifications:

### **Huron 4 Transmixer Truck (cont.)**

#### **Drum**

Concrete output capacity:.....4m<sup>3</sup>  
Direct unloading height:..1465mm  
Unloading height :.....1100mm  
Hydraulic rotation of drum for loading-mixing and unloading is effect by electric speed regulation of rpm.

#### **Water System**

Hydraulic operated self-priming water pump.  
The water is supplied from an external source, taken directly to the drum, to the tank or the washing hose. It can also be taken from the truck mixer tank to the drum or the washing hose. High pressure pump for cleaning purposes. Litre counter.

#### **Max Slope**

Fully loaded: 30% (SAE normative)

#### **Speed**

1<sup>st</sup>.....0 - 8 km/h (for working)  
2<sup>nd</sup>...0 - 20 km/h (for movement)

#### **Steering Radius**

Internal.....4,150 mm  
External.....7,800 mm



*Figure 4 Aliva 302 Spray Boom with 240/360 degree Nozzle Rotation*



*Figure 5 Aliva 302 Spray Arm shooting Shotcrete.*



*Figure 6 Remote Joystick Operation and Controls*

#### **Electrical**

12 V battery 180 Ah, 650A

#### **Tires**

10'00R20 16PR



[www.multicretesystems.com](http://www.multicretesystems.com)

# Multicrete Huron 4

*Aliva® 257 Shotcrete Machine, AL-302 Spray Arm on a Carrier*

## Specifications:

### **Aliva 257 Shotcrete Machine**

The AL-257 is the universal machine for the application of dry- and wet shotcrete in the thin-stream method. The new and very compact design of the machine impresses through its dimensions, weight and performance. With just 750 kg and dimensions as little as a small dry shotcrete machine, the AL-257 fits on the back of the Huron 4 and is easy to operate. With its unbelievable output capacity range from 0.7– 9.6 m<sup>3</sup>/h (with 3 rotor sizes) the machine works on small concrete renovation work as efficient as on big slope protection or in mines. Less maintenance and wear cost makes it the ideal shotcrete machine for all applications.

### **Built in components**

The AL-257 is equipped with a fully automatic lubrication system for the rotor-discs. The rotor-speed is adjusted with a frequency converter and therefore, can be adjusted to every specific need on the job.

### **Sealing system**

The machine is equipped with rotors made of high tech aluminum and is operating with steel - on -steel wear and rotor plates.



*Figure 7 Drum discharge chute to Aliva 257 hopper*



*Figure 8 Aliva 257 Shotcrete Machine.*



*Figure 9 Easy Safe-Steps to access top of Mixer Drum*

Experience has shown up to 10 times less wear on the steel plates, depending on material, output capacity, hose diameter and compressed air supply! This again leads to less down time and wear cost and therefore to a more economical spraying operation.



www.multicretesystems.com

# Multicrete Huron 4

*Aliva® 257 Shotcrete Machine, AL-302 Spray Arm on a Carrier*

## Specifications:

### **Aliva 302 Spray Boom**

The telescope spraying arm Aliva 302 is used for the application of sprayed concrete in mines, small galleries and excavations.

With its simple and rigid construction, the Aliva 302 is very suitable for the mounting onto different types of carriers.

Transport Length.....2.45 m  
 Transport Width.....0.5 m  
 Transport Height..... 2.0 m  
 Weight of Arm approx. ..550 kg

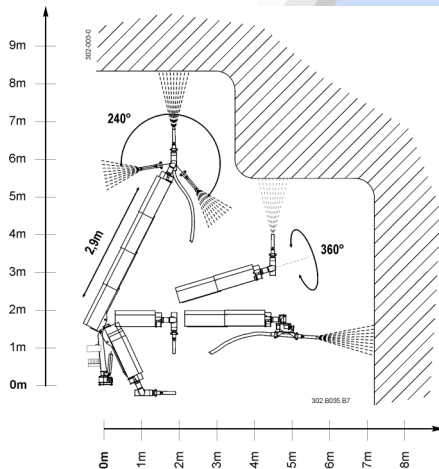

Figure 10 Driving Cage with 180 degree pivot seat



Figure 11 Aliva 302 boom retracted for driving.



Figure 12 Aliva 302 Mounted in front of Engine Compartment

Reach, rotation and precision all contribute to remotely operated quality application of shotcrete material to all of those tough to get into places. Safe workers, minimal hazard, correct technique, less waste, more profitability. The Huron 4 application Shotcrete carrier is your answer.

Winnipeg,MB Redlake,ON Thompson,MB Snowlake,MB Flin Flon,MB Saskatoon,SK Edmonton,AB  
 Ph:204-262-5900 Ph:807-735-3011 Ph:204-677-5977 Ph:204-358-7992 Ph:204-687-6533 Ph:306-651-2727 Ph:780-960-6692

www.multicretesystems.com